

Mini-Road Paver Wheeled AFW 150 G

Unique machine for its applications, ideal for small job-sites.

AFW 150 G offers a combination of original simple design and proven technology. AFW 150 G is particularly successful for small road repairs and for paving areas where cable installation has to be put in place. The compact design allows it to work in a single lane with minimum disruption to traffic and in restricted space applications.



APPLICATIONS

- footpaths
- cycle tracks
- trenches closure
- layers on low weight-bearing surfaces
- alleys in old town
- layers underneath narrow porticos

Three wheel paver, two rears for traction and one front for steering. Fixed hopper, side chargeable by skid-loader. Standing drive on rear platform. Air-cooled diesel engine with electric start/stop, assembled together with the hydraulic pumps. Hydrostatic transmission with variable flow rate pump that feeds two orbital motors. The two orbital motors are fitted to the

planetary drives of the traction. A proportional hydraulic-control, mounted on the variable flow pump, allows the progressive start and stop, by a hydraulic manipulator. Hydraulic steering with lever distributor.

Feeding of material

Conveyor belt with anti-wearing steel slats and hydraulic transmission. One paddle microswitch on the conveyor controls the flow of material.

Screed with options

The mini-paver is equipped with the FSB 150 G screed, gas heated, extendible for a 800–1300 mm layer (option for mechanical extensions for a 1650 mm layer). The extension of the screed is manual, the lifting up and down is hydraulic by a manual lever.



Technical specification

Dimensions:

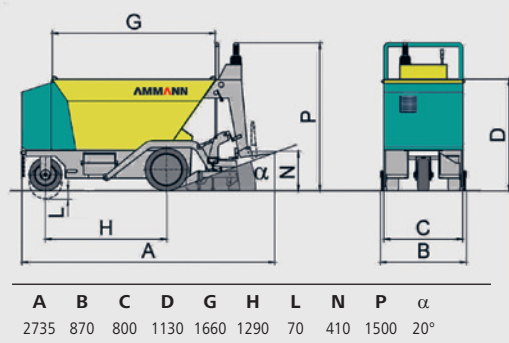

Max paving widths:

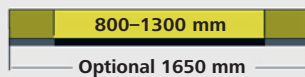

Equipment	
Standard	
Automatic gas burner ignition and temperature control	
Reduction plates for screed paving width at 250 mm	
Optional	
Mechanical extensions (2x175 mm) till 1650 mm	
Vibrating system	
Twin wheels	

Wheeled Paver AFW 150 G

Length (transport)	mm	2550
Dimensions	(see ill.)	
Engine		
Manufacturer	Hatz 1B40	
Type	Air cooling diesel	
No. of cylinders	1	
Power (DIN/ISO 3046/1) at 2600 rpm	kW	6.3 (8.5 PS)
Max torque	Nm 25 at 2000 rpm	
Generator	12 V–14 A	
Brakes		
Service brake	Hydrostatic	
Parking brake/Emergency	Multiple disks negative brake on reduction gears	
Traction – Steering		
Transmission type	Hydrostatic	
Steering type	Hydraulic	
Internal turning radius	m	0.80
Performances		
Spread layer width	mm	800–1300
Max spread layer width (with mech. ext.)	mm	1650
Heating	Gas	
Production	t/h	35
Layer thickness	mm	5–100
Hopper capacity	m ³	0.6
Speed (transfer)	km/h	0–2.5
Tank capacity		
Fuel tank	l	5
Hydraulic oil	l	15
Wheels		
Traction	n° 2 Ø 432 x 127	
Steering	n° 1 Ø 330 x 152	
Weights (CECE)		
Paver with screed	kg	940

